

ATLAS Teamwork: ATLAS Teamwork:

AR 85

AR 35/35 Super



Operation weight 2500 kg / 2875 kg
 Power 24.6 kW (33.5 HP) / 29.4 kW (40 HP)
 Shovel capacity 0.34 m³ / 0.40 m³

AR 40



Operation weight 3300 kg
 Power 29.4 kW (40 HP)
 Shovel capacity 0.50 m³

AR 50



Operation weight 3950 kg
 Power 42 kW (57 HP)
 Shovel capacity 0.70 m³

AR 60



Operation weight 4650 kg
 Power 47.5 kW (65 HP)
 Shovel capacity 0.85 m³

AR 65 Super



Operation weight 4800 kg
 Power 51.3 kW (70 HP)
 Shovel capacity 0.80 - 1.00 m³

AR 75



Operation weight 5600 kg
 Power 55 kW (75 HP)
 Shovel capacity 1.00 m³

AR 75 S



Operation weight 6000 kg
 Power 55 kW (75 HP)
 Shovel capacity 0.80 m³

AR 80



Operation weight 5750 kg
 Power 59.3 kW (81 HP)
 Shovel capacity 1.00 m³

AR 85



Operation weight 6700 kg
 Power 71.2 kW (97 HP)
 Shovel capacity 1.30 m³

AR 95/95 Super



Operation weight 7900 kg / 8100 kg
 Power 74.9 kW (102 HP) / 92 kW (125 HP)
 Shovel capacity 1.40 - 1.60 m³

Technical data without engagement.
 Subject to change without notice.

ATLAS
 WEYHAUSEN

ATLASWEYHAUSEN GmbH
 Maschinenfabrik
 Visbeker Straße 35
 D-27793 Wildeshausen
 Telephone +49 (0)44 31/981-0
 Fax +49 (0)44 31/981-225
 www.radlader.com

01/2010



- Construction trade, recycling, material handling, civil engineering works and road construction
- Operating weight: 6700 kg
- Power: 71.2 kW

ATLAS
 WEYHAUSEN

TECHNICAL DATA AR 85

Engine

Make:	TCD 2011 L04W
Type:	water cooled
Power ^{***} :	71.2 kW (97 hp) at 2300 min ⁻¹
Max. torque:	333 Nm at 1600 min ⁻¹
Stroke:	3619 cm ³
Cylinders:	4 in line
Electrical System:	
Operating voltage:	12V
Battery:	12V/ 100 Ah
Alternator:	14V/95 A
Starter:	12V/2.3 kW

Drive

- Output regulated hydrostatic drive with pressure cut off and closed circuit acting on all 4 wheels
- Speed with standard tires:
 - Operating speed range 0–6.5 km/h Road speed range 0–20 km/h
 - Optional high speed 0–40 km/h
- 1st and 2nd hydraulic gear can be engaged under load, forward/backward travel also
- Activation of forward/backward travel and speed ranges via ATLAS joystick
- Drive operated by accelerator and separate inching pedal for best distribution of the hydraulic power for thrust and lifting forces

Axles

Rigid axles with planetary reduction gears in the wheel hubs, electrically connecting 100% - differential lock in front and rear axle.

Brakes

Standard brake: Multi-disc brake in oil bath acting on all 4 wheels. Supplementary brake function via inching pedal and hydrostatic drive acting on all 4 wheels.

Parking brake: Parking brake as spring-loaded brake acting on all 4 wheels. In case of standstill of engine the spring-loaded brake will be automatically re-activated.

Steering

- Fully hydraulic center pivot steering
- Front and rear wheels follow the same track
- Steering angle 40° to each side, ±12° angular movement in rear of vehicle
- Operating pressure of steering hydraulics 175 bar
- Emergency steering function

Hydraulic system

- Gear pump for loading and steering hydraulics
- Priority valve favoring steering hydraulics
- Lowering brake dependent on load
- Two lifting and tipping cylinders each
- 3rd section serial
- Loading hydraulic hydraulically pre-activated via ATLAS joystick including float position
- Operating pressure 225 bar
- Delivery of pump 69 l/min

Loading equipment

- Powerful and solid Z-kinematics with high tear out force
- Hydraulic quick change device
- Activation of all functions via ATLAS joystick
- Parallel movement while using pallet forks
- Automatic shovel return to excavating position
- Locking device acc. to German StVZO for road travel
- Lifting 6.0 s
- Lowering 4.1 s
- Tipping 1.2 s

Standard equipment

- Rear driving mirrors, foldable
- Heatable rear screen
- Comfortable access to cab from both sides
- Single lever operation via ATLAS joystick
- Control lights for speed range, forward/backward travel
- Lights acc. to German StVZO for road travel
- Individually adjustable driver's seat with adjustable right arm rest
- Engine water heating with heat exchange and 4-stage fan
- Front windscreen ventilation, variable output
- Sound absorbing ROPS-cab
- Parallel windscreen wipe and wash unit in front and rear
- Sun visor, coat hook, ceiling lamp, stow facility
- Adjustable steering column
- Heat protection glazing with large tinted screens
- Control lights for engine oil pressure, overheating, hydraulic oil temperature, battery power, parking brake, air filter
- Central dashboard with indicators for preheating, engine temperature, fuel, working hour meter

Options

- 4th section front or rear
- Stability damping system
- Slow drive inching pedal
- High speed version 40 km/h
- Extended lifting frame
- Hand throttle device
- Load brake security
- Trailer coupling
- Load check valve for lifting and working cylinders
- Main battery switch
- Corrosion protection for salt

- Special colors and oils
- Heatable and air cushioned seats
- Joystick with integrated proportional steering for 3rd section (only ADS)
- Auxiliary heating, comfort cab, canopy-cab
- ATLAS diagnostic system (ADS) for monitoring engine parameters with integrated electronic anti-theft device
- Extra seat
- Radio
- Warning beacon
- Doors with sliding windows right and left
- Anti-theft device with code stick

More options upon request

Tires

Standard:

405/70 R 24 EM – Construction machine tires for clay, sand, gravel, asphalt, roads, gardening and landscaping

Special tires:

460/70 R24 XMCL – Construction machine tires for clay, sand, gravel, fields and greenland, fortified roads

More special tires upon request

Fuel/oil capacities

Diesel:	120 l
Hydraulic oil:	86 l
Engine oil:	11.0 l
Front axle:	4.5 l
Rear axle:	4.2 l
Gear oil:	2.5 l
Cooling fluid:	11.0 l

Operating data

Shovel capacity acc. to SAE:	1.3 m ³
Track width:	1640 mm
Turning radius (outer shovel edge):	4660 mm
Tear out force:	6800 daN
Torque:	5700 daN
Tipping load, straight:	5408 kg
Tipping load, articulated:	4798 kg
Lifting capacity at ground level:	6000 daN
Service weight:	6700 kg

Differing data for use of pallet forks (500 mm distance to center of gravity)*

Static tipping load, straight and articulated:	3925 kg
Lifting capacity:	5100 daN
Payload 80% even surface ^{**} :	3140 kg
Payload 60% uneven surface ^{**} :	2355 kg

* Travel with load only permitted close to the ground.

** According to ISO 8313 and EN 474-3

*** According to ISO 1585, resp. to EG-RL80/1269/EWG and EG-RL88/195/EWG.

Specific gravity for material handling

material weight (t/m³)

Construction

concrete	1.9
soil (dry)	1.5
soil (watery)	2.0
rock (fill)	2.4
granite	1.8
limestone	1.6
gravel (dry)	1.9
gravel (watery)	2.1
loam	1.7
plaster	2.2
sand (dry)	1.9
sand (watery)	2.1
sandstone	2.4
shale	2.2
sediment	2.1
crushed stone	1.5
de-icing salt	1.3
clay	1.6
cement	1.7
clinker (stacked)	1.8

Industry

ember	0.7
brown coal briquette	0.8
ferrous product	7.8
iron ore	2.3
cullet	1.9
gas coke	0.4
timber	0.8
mineral coal	1.2
paper	0.9
slag	1.0
slag concrete	2.7

Landscaping, agriculture

agricultural crop	0.7
grain	0.6
hay	0.3
potash	1.1
compost	1.0
flour	0.5
clay (watery)	2.3
phosphate fertilizer	2.2
turf (watery)	1.1
turf (dry)	0.4
mineral fertiliser	1.0

Technical data with standard shovel.

AR 85

A	5650
B	2800
B ₁	2035
C	4440
C ₁	3520
C ₂	2700
D	40
E	740
F	510
G	2280
H	2050
I	2250
R	2072
R ₁	4234

All specifications in mm

α 40°

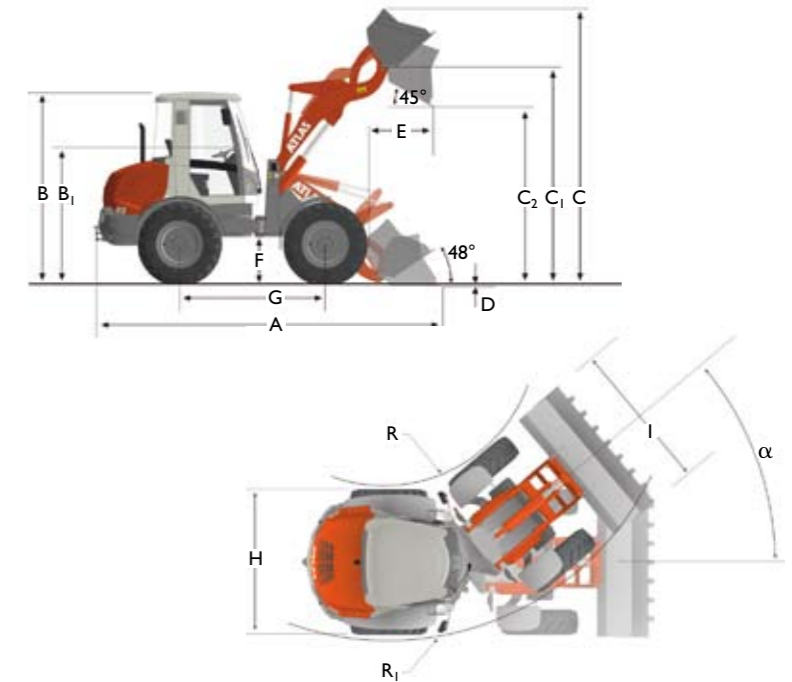

Technical data with pallet forks.

AR 85

A	5750
B	2800
B ₁	2035
C	3765
C ₁	3310
C ₂	1605
D	60
E	450
E ₁	1170
E ₂	580
F	510
G	2280
H	2050
I	1030
R	2072
R ₁	4234

All specifications in mm

α 40°

